

LeanOne TOOL

Multifunctional

The ANYTARY LeanOne Tool can handle up to 67% more trays per stack than other denesting products, and its system is applicable for both tightly packed stacks of trays as well as the more fragile ones. The same tool is used for buffer and rack solutions.

Easy to Integrate

The tool is easy to integrate into existing production lines, regardless of what type of trays is used.

The lightweight tool furthermore provides an easy one-minute changeover, ensuring reduced downtime.

Hygienic Design

The hygienic design of the ANYTRAY LeanOne Tool makes cleaning and maintenance easy and efficient. This ensures a clean production area.

PNEUMATIC DENESTING SOLUTION

QUPAQ

QUALITY QUANTIFIED

Specifications

ANYTRAY LeanOne Tool - Buffer

Capacity	Air Consumption	Air Pressure	Humidity	Operational Temperature
Up to 120 trays per minute	300 L/min at 120 trays per minute	6 Bar	Min. 10% Max. 90%	0°C - 60° C 32°F - 95°F

Noise Level	Weight	Steel Quality	Maximum Tray Length	Maximum Tray Width
< 70 dB	Approx. 12 kg (tray dependent)	EN 1.4301 AISI 304	325 MM (tray dependent - please send a request for other sizes)	265 MM (tray dependent - please send a request for other sizes)

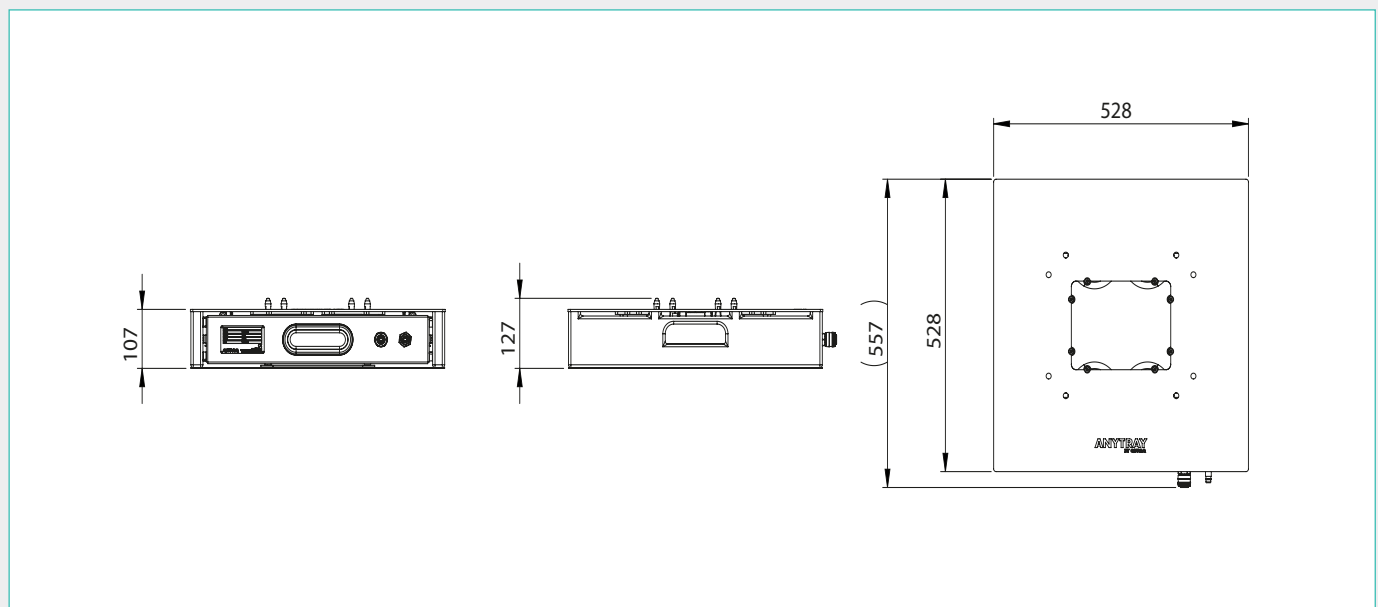

Specifications and photos are intended as a guide and can be changed by QUPAQ without notice. We make reservations for misprints and typing errors. The illustration and specifications are of the ANYTRAY LeanOne Tool - Buffer. Item no. 91300028.

QUPAQ

QUALITY QUANTIFIED

QUPAQ
Erhvervsparken 16
9700 Broenderslev
Denmark

P. +45 96 46 76 00
qupa@qupa.com
qupa.com