

ANYTRAY Portion-2-Pack 135 For ANYTRAY CleanLine Denester

CS-21.09

The Portion-2-Pack 135 compact system is designed for high volume production of batches, of minced products.

Automatic trayfilling

Portion-2-Pack 135 is an automatic tray filling system, that forwards portions/product from your portioning system, fills the portions/product into trays, and delivers it to your tray sealer at a speed up to 135

trays per minute, in a minimum of space. With the compact design, the machine is easily integrated in the existing Production Line. The system is able to handle trays of different sizes and shapes.

Main features

- Capacity up to 135 trays per minute (tray depending)
- Easily integrated into existing production/packing lines

- Includes an intelligent electrical control system
- Automatic refilling of trays into the denester
- Few moving parts
- Low maintenance costs
- Hygienic design
- Short return of investment

Technical specifications

ANYTRAY Portion-2-Pack 135

CS-21.09

Weight of machine	Approx. 450 kg	Max short circuit current (Ik max)	6 kA
Tray length - max length	325 mm	Voltage for valves	24 V DC
Tray width - max width	265 mm	Air consumption	200 L (120 trays/min)
Infeed height	800 mm +/-150 mm	Air pressure	6 Bar
Outfeed height	800 mm +/-150 mm	Operational temperature	32°F-95°F/0°C-60°C
Power supply	3x400 VAC+N+PE	Stock temperature	14°F-140°F/-10°C-60°C
Power consumption	3 A	Humidity	10%-90%
Max fuse	13 A	Noise level	< 80 dB (A)
Frequency	50 Hz	Steel quality	AISI 304

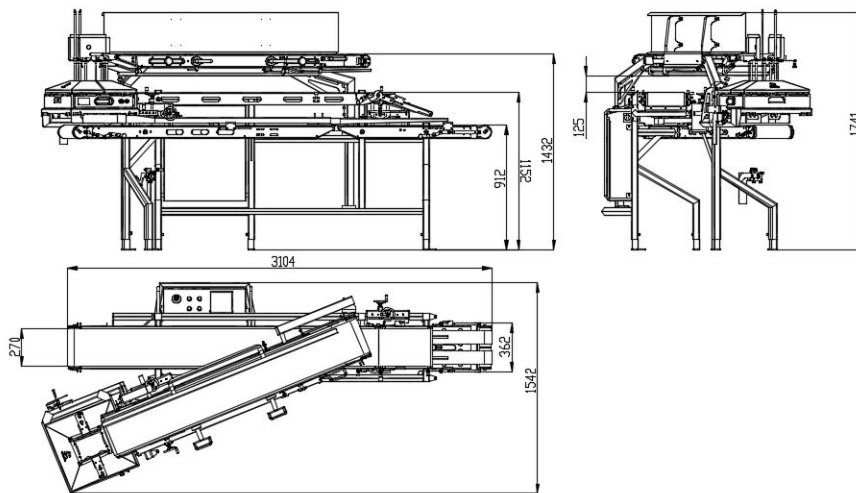

Specifications and photos are intended as a guide and can be changed by QUPAQ without notice. We make reservations for misprints and typing errors.