

## ANYTRAY CleanLine Single Rack With ANYTRAY CleanLine Denester

CS-10.01

### A flexible solution

The ANYTRAY CleanLine Single Rack is a stand prepared for the ANYTRAY CleanLine Denester.

It is supplied with electrical/pneumatic control panel. A flexible solution, for easy moving your production from manual labor to an automatic solution with a simple machine from the ANYTRAY product range.

### Main features

- Max capacity is up to 120 trays per minute - depending on tray shape and size
- Easily integrated into existing production/packing lines
- Full external control over denesting speed
- Few moving parts
- Low maintenance costs
- Hygienic design
- Short return of investment

- Easy, one-minute changeover from one tray size to another

### Option

- Moveable on four wheels, two with brake

# Technical specifications

## ANYTRAY CleanLine Single Rack

CS-10.01

Weight of machine	Approx. 55 kg	Max short circuit current (Ik max)	6 kA
Tray length - max length	360 mm	Voltage for valves	24 V DC
Tray width - max width	280 mm	Air consumption	300 L (120 trays/min)
Infeed height	1000 mm +/-350 mm	Air pressure	6 Bar
Outfeed height	1000 mm +/-350 mm	Operational temperature	32°F-95°F/0°C-60°C
Power supply	1x100-240 VAC+N+PE	Stock temperature	14°F-140°F/-10°C-60°C
Power consumption	0.5 A	Humidity	10%-90%
Max fuse	10 A	Noise level	< 80 dB (A)
Frequency	50-60 Hz	Steel quality	AISI 304

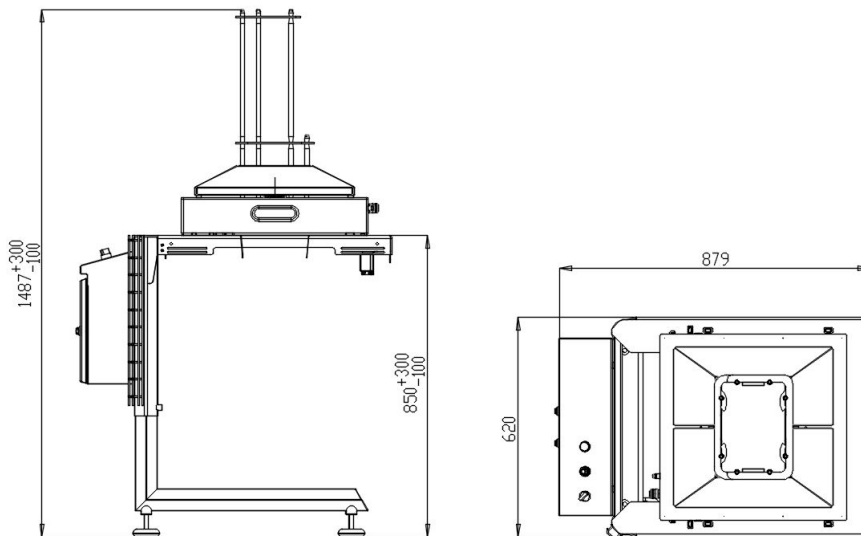

Specifications and photos are intended as a guide and can be changed by QUPAQ without notice. We make reservations for misprints and typing errors.